

English



# vision ES-PLUS



## TECHNICAL MANUAL







**Vision Es-Plus // Vending**



## ÍNDICE

1.	Symbols .....	4
2.	Operating conditions .....	4
3.	Description of components .....	4
3.1.	Main technical features .....	6
3.1.1	Door.....	6
3.1.2	Cabinet.....	6
3.2.	Volume and weight.....	11
4.	Electric-electronic specifications ✎.....	12
4.1.	Initial electrical installation ✎ .....	12
4.2.	Product dispenser channel.....	13
4.3.	Control card.....	13
4.4.	Relay card.....	14
4.5.	Electronic thermometer card.....	14
4.6.	Elevator product detector photocell cards .....	14
4.7.	Electronic control system .....	14
4.8.	Machine electrical drawing.....	16
5.	Installation and start up.....	17
5.1.	Installation.....	17
5.2.	Start up.....	17
5.3.	Restocking machine trays .....	17
5.4.	Updating the machine program .....	18
6.	Operation.....	19
7.	Troubleshooting.....	19
8.	Annexes.....	21
8.1.	Transport feet and adjustable levelling feet.....	21
8.2.	Cleaning and Maintenance.....	21
8.3.	Recyclable.....	22
8.4.	Environment  .....	23
9.	Regulation .....	23

## 1. Symbols

	This symbol means there are more detailed explanations on this subject elsewhere in the manual.
	This symbol means that the text in question refers to programming.
	This symbol indicates very important information.
	This symbol is a warning of high voltage hazard.
	This symbol indicates that a given material should <b>not be disposed of as domestic waste</b> .
	This symbol indicates that a given material is <b>recyclable</b> .
	This symbol indicates that <b>Jofemar</b> is committed to the <b>environment</b> .

## 2. Operating conditions

This machine has been specifically designed to work in interiors. The machine leaves the factory adjusted to work properly at an ambient temperature between **5° C (41° F) y 32° C (89.6° F) 5° C and 32° C** with a maximum humidity of **60%** and a maximum load of **100 kg (220 lb)** of products.

## 3. Description of components

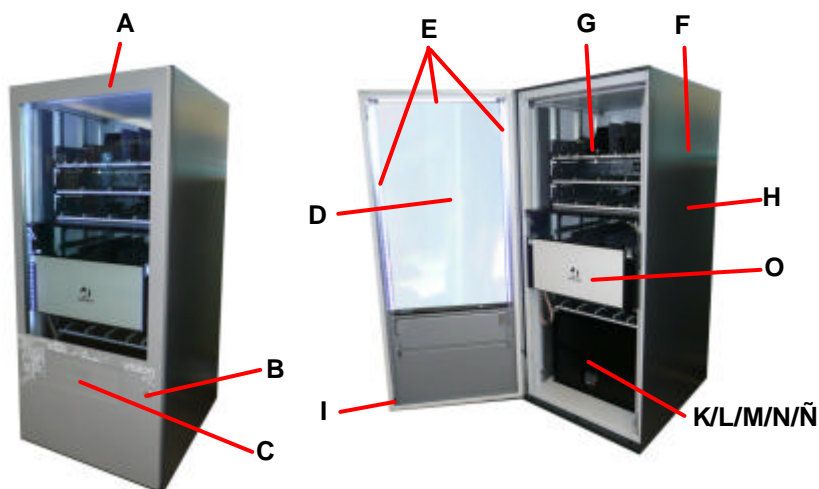



N



K

M

N

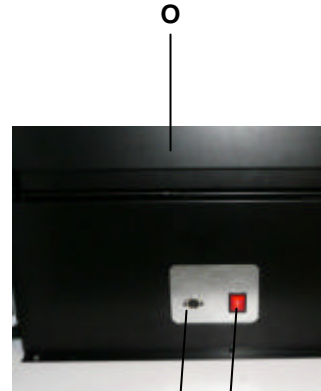

O

K

M

**WITH COOLING UNIT**

**WITHOUT COOLING UNIT**

MAIN SWITCH POSITION AND RS-232 CONNECTOR

WITH COOLING UNIT

WITHOUT COOLING UNIT

Posición	Descripción	Posición	Descripción
A	Door	I	Door microswitch
B	Lock	J	Electronics support
C	Product delivery opening	K	RS-232 connection
D	Safety glass	L	Fuse/Fuse holder
E	Iluminación Leds	M	Main switch
F	Cabinet	N	Cooling unit
G	Trays and channels	N	Turbine
H	Elevator	O	Photocell scanning assembly

## 3.1. Main technical features

- ? Dispenses a wide range of products of different sizes and shapes —different types of drinks and snacks, sandwiches, different objects, glass bottles, bread, egg cartons, etc.
- ? Flexible configuration and programming, up to 8 height-adjustable trays with up to 10 channels each for including various product formats.
- ? Adjustable internal temperature.
- ? The metal parts are constructed in 0.8 mm (0.031") thick galvanized steel, with outer a weather-proof PVC coating.

### 3.1.1 Door

The metal parts are constructed in 1,2 mm (0.047") thick galvanised steel, with rustproof protection and an external coat of rustproof paint.

On the front of the door you can see the following: the safety glass, lock and product delivery outlet. On the back of the door you can see: the door microswitch, three LED strips, and the product delivery door stop.

#### Safety glass



Fig. 01

Made of double glazed, low emission **climalit** safety glass with a 12 mm (0.472 ") gap offering top strain reliability.

It provides a view of the products and their location on the trays.

	Height (H)	Width (W)	Thickness (F)
<b>Vision Es - Plus</b>	1.169,5 mm. (46.043")	714 mm. (28.043")	22 mm (0.866")

#### Lock

These machines feature a secure locking system consisting of a plate with three vandal-proof anchoring points.

### 3.1.2 Cabinet

The cabinet holds the product trays, the vault, the electronic control system, the cooling unit (for vision Easy Combo) and the product delivery bin.

The structure of the cabinet is injected with polythene foam for improved insulation and better consistency.

Trays and channels



There are two types of trays and they are the part of the machine where the product is stored, as there are various configurations, one machine can have up to 8 trays maximum depending on the products that you wish to dispense.

Fig. 02

TRAYS	Dimensions			Weight
	Height (H)	Width (W)	Depth (D)	
Large	115 mm (4.527")	642,2 mm (25.283")	675 mm (26.574")	5,250 Kg 11.55 lb

Capacity up to 10 channels per tray depending on configuration.

Large tray with 1 to 10 channels



Fig. 03

The **vision** machines sell the products shown in the following table:

vision	SNACKS	DRINKS	SANDWICHES	PRODUCTS
Vision Es-Plus	Sachets	Cans		Large Products
	Sweets	Bottles		
	Pastries	Tetra bricks	Of any type	
	Chocolates	Dairy products		

**NOTE:** For other types of products or special sizes please contact your **Jofemar** distributor.

**IMPORTANT:** The minimum size for dispensing in this machine is the size of a tobacco package 23mm x 55mm x 88mm (0.905" x 2.165" x 3.465").

## **Electronic control system**

It consist of several printed circuit cards:

- **Control card**, which governs all of the machine's movements, and contains the power supply that provides the appropriate voltages for the logic control to move the trays motor, to move the elevator motor to move the motor the verifier of the product detector and to feed the product detection system. The program is recorded in FLASH memory
- **Relay card**, which has the relays that control the connection to the compressor, electrovalve and showcase light.
- **Photodiode and phototransistor cards** of the product detection system.
- **Photodiode and phototransistor cards** to control the position of elevator.
- **Electronic thermometer card** for machines with refrigeration unit.

## **R 134A CFC-free cooling unit (Es-Plus)**

It is managed by a program which controls the temperature of the machine product hold electronically.

The machine is equipped with a cooling unit and a turbine to keep a constant working temperature in the product hold. This temperature, also called cooling unit cut-off temperature, is programmable on the master machine. When the internal temperature rises 2.5 °C (36.5° F) above the cooling unit cut-off temperature, the cooling unit turns on. When the internal temperature again matches the cut-off temperature, the cooling unit turns off.

The cooling unit consists of a compressor and a condenser located in the lower part of the cabinet, as well as an evaporator located inside the product hold and an axial flow fan that cools the condenser and the compressor motor. The cooling gas used is the gas indicated on the machine compressor. The turbine is a fan with two runners located inside the product hold which is permanently in operation.

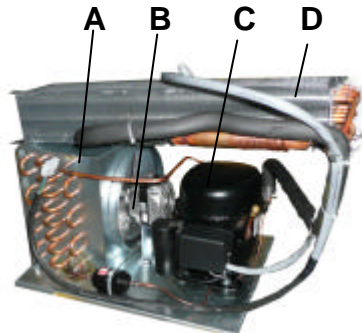

A. Condenser
B. Fan
C. Compressor
D. Evaporator

Fig. 04

The machine carries out defrosting cycles to prevent ice from building up in the evaporator of the cooling unit, which would have adverse effects on the unit's performance. The defrosting cycle consists of turning the cooling unit off long enough for the ice build-up on the evaporator to disappear. The machine performs a defrosting cycle out a day at approximately 8-hour intervals. The defrosting cycle is initiated when the machine has been restocked with product, in order to prevent the product from not being shown on the display until one hour after the defrosting cycle is completed.

There is a window to permit air circulation through the inside area where the compressor and condenser are located. It is located at the back of the machine cabinet. For proper operation of the cooling system the window should be kept free of dust and you should check regularly that it is not obstructed by foreign objects, such as bags, papers, etc.



Fig. 05

The indoor temperature can be programmed in the MASTER level machine option between 0.5 °C (32.9 °F) and 12 °C (53.6 °F).

**GROUP PRESSURE TESTING** To check the pressure of the cooling unit, remove the black cap, where the head of the core is located. Connecting a pressure gauge and get a pressure reading.

**Note:** For safety reasons, every time the unit is stopped and started, the process is detained during a 4-minute interval.

## Elevator

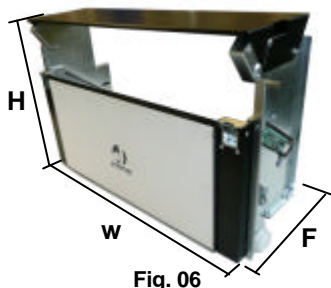

Dimensions		
Height (H)	Width (W)	Depth (D)
455 mm (17.913")	715 mm (28.149")	265 mm (10.433")

It has a product detection system based on infrared emitters and phototransistors. This way, when the infrared beam is cut off, it means there is a product inside the elevator.

### Elevator product detector checking assembly



Fig. 07

A system consisting of a motor, a microswitch, a cam movement and a door that turns in a full circle and is positioned in the same location through a microswitch. Verify that the elevator detected the door rotation with the photocells and that there is no obstacle in the elevator.

### Lighting

The machine is perfectly illuminated by three LED strips that are located on the door (fig. 8). The LEDs are encapsulated and protected to withstand various conditions of humidity, condensation, etc.

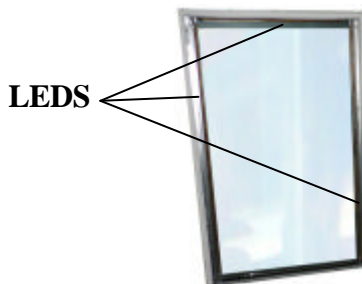

Fig. 08

### Anchoring

These machines are fitted with holes and supplied with an anchoring kit (fig. 9) that can be used to anchor the machine to the floor (fig. 10) or to the wall (fig. 11) for greater stability and support and to prevent thefts.



**Fig. 09**



**Fig. 10**

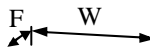

**Fig. 11**

**3.2. Volume and weight**

Dimensions	Height (H)	Width (W)	Depth (D)	Weight
Vision Es-Plus (with cooling unit)	1.825 mm (71.850")	800 mm (31.496")	1010 mm (39.763")	306 Kg 671 lb
Vision Es-Plus (without cooling unit)	1.825 mm (71.850")	800 mm (31.496")	975 mm (39.763")	726 Kg 1597.2 lb

\* The weight of the machine is for with a 5 tray configuration.





Vision Es-Plus  
Fig. 12

#### 4. Electric-electronic specifications ✎

The cooling assembly, LED lighting power supply, turbine and transformer are supplied with the mains voltage for the particular country where the machine is sold. They should therefore not be handled without disconnecting the machine from mains.

vision	Power supply voltage	
	230 ± 10% VAC. 50 Hz	
	Maximum power	Maximum intensity
Es-Plus (without cooling unit)	100 W	0,4 A
Es-Plus (with cooling unit)	830 W	3,5 A

vision	Power supply voltage	
	110 ± 10% VAC. 60 Hz	
	Maximum power	Maximum intensity
Es-Plus (without cooling unit)	100 W	0,4 A
Es-Plus (with cooling unit)	830 W	3,5 A

#### 4.1. Initial electrical installation ✎

Prepare a socket, protected with an automatic connection system. The socket should match the machine plug (European, with ground connection). Follow all Low Voltage Installation Regulations and check that ground connection works properly once the machine has been installed.

### 4.2. Product dispenser channel

There are three types of different product dispensers. Depending on the type of product to be served, you can interchange these channels, offering a wide range of combinations. A maximum of 10 dispenser channels can be added to each tray.



Fig. 13



Fig. 14



Fig. 15

Ref. code	8210061 (Fig. 22)	8210062 (Fig. 23)	8210063 (Fig. 24)
Motor power supply	12 Vcc	12 Vcc	12 Vcc
Max. power consumption	3w	3w	3w

To properly dispense a product, the dispenser motor operation voltage has to be programmed on the master machine to ensure the most appropriate dispensing speed for each product.

### 4.3. Control card

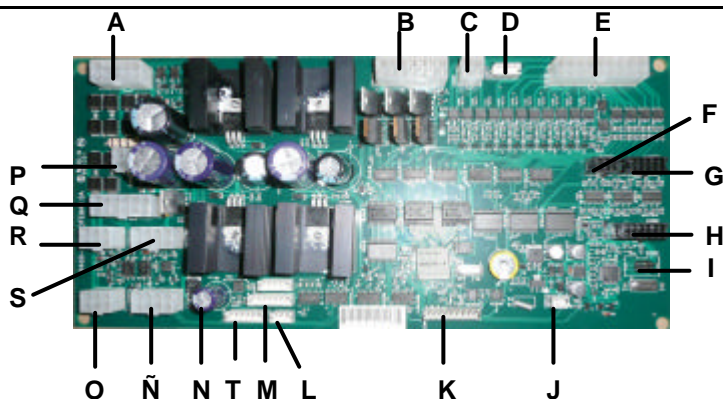

Fig. 16

CONNECTION CONTROL CARD	
A. Transformer secondary and relays	K. (Not in use)
B. Connection elevator	L. Door microswitch connection
C. Connection tray motors	M. RS-232 port connection (1)
D. (Not in use)	N. RS-232 port connection (2)
E. Connection tray motors	N. (Not in use)
F. (Not in use)	O. Set slave number
G. (Not in use)	P. (Not in use)

H. Thermometer connection	Q. (Not in use)
I. (Not in use)	R. Set slave number
J. Battery connection (temperature controller)	S. (Not in use)
	T. Connection to master

#### 4.4. Relay card

RELAY CARD CONNECTORS
A. Cooling unit enabling and lighting
B. Control card power supply
C. (Not in use)
D. Transformer connection

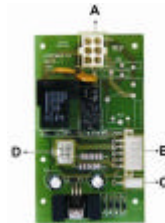

Fig. 17

#### 4.5. Electronic thermometer card

The temperature of the product hold is measured with an electronic thermometer which can be placed in different locations of the product hold. Normally, it is located half way up the hold.



Fig. 18

#### 4.6. Elevator product detector photocell cards

A. Transmitting car
B. Detecting card



Fig. 19

#### 4.7. Electronic control system

The electronic control system is in the lower part of the cabinet. To access it you need to previously remove the elevator product detector checking assembly.

In the case of refrigerated machines, you also have to remove the insulated cover that protects the control card.

<b>POWER BOX VISION ES-PLUS</b>	<b>220 Vac</b>
<b>Main switch</b>	Bipolar
<b>EMI filter</b>	3 A.
<b>Transformer power</b>	100 W
<b>Transformer primary</b>	220 Vac
<b>Transformer secondary</b>	24 Vca , 15 Vca , 11Vca
<b>220 Vac mains protection fuse</b>	10 A.

<b>POWER BOX VISION ES-PLUS</b>	<b>110 Vac</b>
<b>Main switch</b>	Bipolar
<b>EMI filter</b>	3 A.
<b>Transformer power</b>	80 W
<b>Transformer primary</b>	110 Vac
<b>Transformer secondary</b>	24 Vca , 15 Vca , 11Vca
<b>110 Vac mains protection fuse</b>	15 AT.

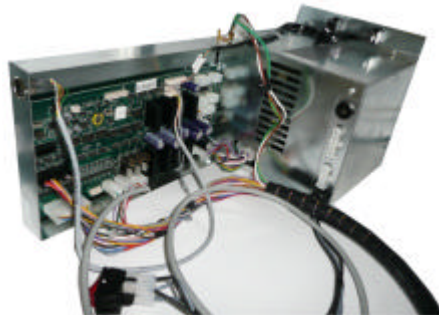

**Fig. 20**

## 4.8. Machine electrical drawing

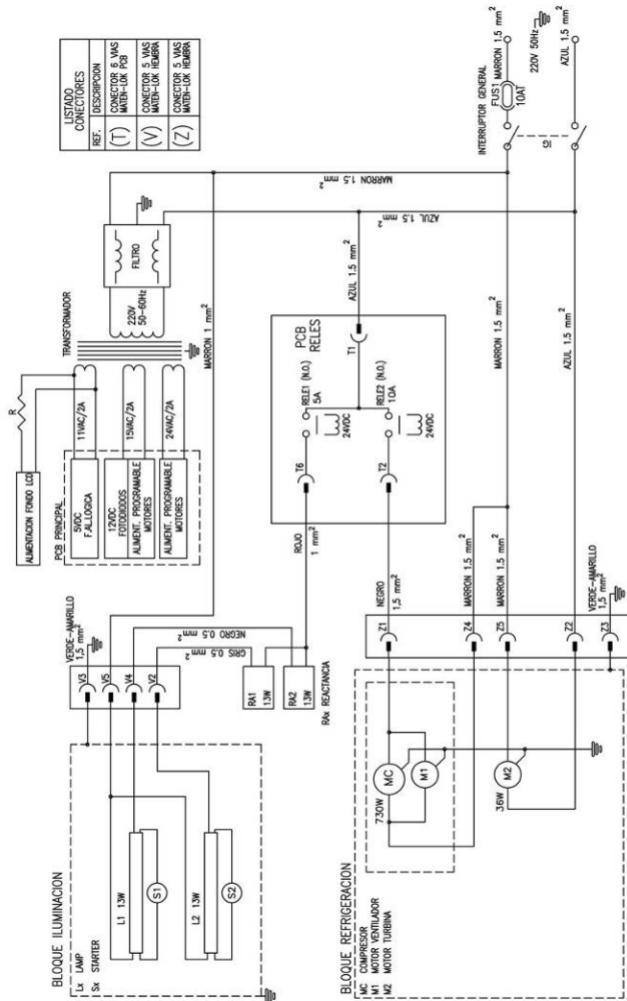

## 5. Installation and start up

### 5.1. Installation

Do not install the machine near active heat sources (heaters, radiators, etc.). Avoid obstructing the grids located at the front of the cabinet to ensure air circulation inside, where the cooling unit motor is located (if the machine has one). Leave a distance of at least 7 centimetres between the back of machine and the wall or other items .

In 24 hour vending facilities, make sure that the hot air coming out of the machine at the back can be easily discharged, i.e., that the machine is properly vented at the back.

Efficient removal of hot air significantly reduces the power consumption of your machine and hence your electricity bill.



**IMPORTANT:** It is important for the machine to be level, as it should operate in a vertical position, both laterally and front-to back, placed so the mains plug is readily accessible and with a maximum tilt of 5% ( $\sim 2^\circ$ ). This will also prevent noise and vibration and will extend the cooling unit service life.

### 5.2. Start up

As a safety measure to avoid damaging the cooling circuit (if the machine has one), wait to connect the machine to mains for 2 hours after finishing unpacking and installing the machine.

### 5.3. Restocking machine trays

Open the machine door, press the tray anchoring system (on the side), slide out the tray to be restocked and place the products in their channel until all of the machine's trays have been restocked.

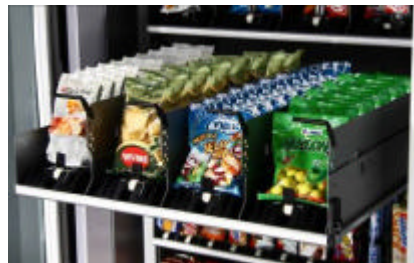

Fig. 21

## 5.4. Updating the machine program

The control card of the machine has been designed to use flash technology. This feature allows you to update the card program. To perform this task you need to manually lift the machine elevator until you can see the RS-232 connector. Program updating can be done through a PC or an EasyFlash reprogramming device.

### ! USING A PC

**Follow these steps to update the program:**

- 1.- With the machine turned off, connect the PC to the machine using the RS-232 cable.
- 2.- Choose the program to install in flash memory:
  - The program files should be stored in the subdirectory of the hard drive corresponding to the VISION V3 machine.
  - Run the PC program. Choose the menu option FLASH - RECORD - VISION V3 and choose the \*.h00 file.
- 3.- Turn the machine on.
- 4.- When the program has been updated, a message will appear on the PC screen indicating that the flash memory has been successfully recorded.

### ! ⓘ USING THE EASYFLASH REPROGRAMMING DEVICE

**Follow these steps to update the program:**

- 1.- With the machine turned off, connect the EASYFLASH device to the machine using any of the cables supplied.
- 2.- As soon as the program is loaded, it will load the data from the file TYPES.DAT for the machines with which you wish to communicate.
- 3.- The first thing the program requests is the type of operation you wish to carry out.
  - **Recording a program in flash memory.**
  - Erasing the card's flash memory.
  - Identifying the program recorded in a card.
- 4.- After choosing the operation, you have to select the machine with which you wish to communicate.
- 5.- You need to select the file you are going to record.
  - The program can work with two standard reference file formats, .HEX (Intel) and .BIN. When the program has more than one bank, the file extensions will be .H00, .H01, .H02 ... (or .B00, .B01, .B02 ...) and so on until all banks are completed. In these cases, the program will only show the file of the first bank (.H00 or .B00).
  
  - When you select a file, if the extension is .HEX or .BIN the program will know that there is only one bank, while if it is .H00 or .B00 it will search for files with consecutive extensions until it does not find any more (maximum .H09 or .B09) and the number of files will be the number of banks recorded.
- 6.- After all the data has been recognised, the program will begin the operation chosen.

- This process is divided in two parts, the first is erasing the flash memory and the second is the program recording.

7.- When the recording program has finished communicating with the machine, a new window will appear showing the result of the process.

(For more information, consult the manual of the EASYFLASH reprogramming device)

## 6. Operation

For the correct operation of the ES-Plus slave machine, it must be connected to a MASTER machine or to an external payment module with the appropriate software to control this type of slave machine. Once the MASTER machine communicates with the slave machine, the MASTER machine or MASTER module software will determine how the slave machine is to function (extraction, self -tests, manual handling etc.).

## 7. Troubleshooting

The following table will help you solve the most common machine failures. It describes a series of anomalies, their possible causes and the steps to take in solving them or in determining the cause of such failures before contacting our customer service.

FAULT	CAUSE	SOLUTION
? The MASTER machine or MASTER module does not detect the slave machine.	? Incorrect wiring connection between them.	? Check the connection cable between the two machines and the internal connections of the cable with the control card of the slave machine.
? No sales are made from any channel in the machine.	? Machine out of service because of elevator break down, product detection system fault or because there is no motor connected.	? Check the fault in the MASTER machine checking address. ? Should there be a fault in the elevator due to a jam, remove it and reset the fault in the relevant address of the MASTER machine. ? If the lift motor does not move properly check if it is getting power when you try to move it via the manual handling address of the MASTER machine. If there is no power supply, check the wiring and control card. Otherwise, replace the

		<p>motor.</p> <p>? In case of fault in the product detector, check whether the product detection LED indicator product is always on. If it is, you may have dirt in the slots that the elevator has to allow the infrared beam through. Otherwise, place an object inside the elevator and check whether the product detection LED indicator turns on. If it does not, there may be a faulty transmitter or receiver card or an incorrect card power supply due to a defect in the wiring.</p> <p>? If no motor is connected, check tray connections.</p>
? No sales from a channel with product.	? Problems with the inside door opening switch.	? Check that the inside door opening switch works properly, as otherwise, the out of product marks will not be erased.
? Internal temperature is not correctly regulated.	<p>? Problems with the electronic thermometer or wiring.</p> <p>? Problems with the cooling unit.</p>	<p>? Check the MASTER machine screen for the relevant programming option for the internal temperature value to see whether the thermometer reading is correct. If not, check the wiring. If there is something with the wiring, fix it or replace it and if it is OK, replace the electronic thermostat.</p> <p>? Contact our technical support service.</p>

## 8. Annexes

### 8.1. Transport feet and adjustable levelling feet

Once the machine is on the ground, it is advisable to remove the four (plastic) transport feet for better stability, aided with the lifting jack as follows:

1° Raise the back, unscrew and remove the two plastic feet and let the machine rest on the floor.

2° Open the machine door 90 degrees and raise the front end, unscrew the two plastic feet and replace them with the two adjustable levelling feet, making sure that these are fully screwed onto the base of the machine, and then roll the machine on its wheels to the desired position.

3° Once the machine has been placed in its permanent position, raise the front again with the lifting jack and level the door of the adjustable levelling feet (left and right see fig. 22), with this system you can help to level the door perfectly, thereby preventing scarping of the door.



Fig. 22

### 8.2. Cleaning and Maintenance

To ensure the machine works properly at all times, we recommend that the following components be cleaned periodically:

? The outside glass should be cleaned periodically with a moist cloth or sponge and a neutral product suitable for cleaning glass.

? The elevator should be cleaned whenever a product is spilled on it with a cloth moistened with water and you should check that the moving parts are not obstructed.

? Whenever there is a spill in the product delivery bin, it should be cleaned with a cloth moistened with water and all moving parts should be checked to ensure that they move freely.

? If there is a spill on a tray, remove the tray from the machine and clean it using a cloth moistened with water, never with alcohol or acids. Remove the channels from their slots to better be able to clean the whole surface. Check that the belt moves freely and that it

is not obstructed anywhere along its path. Wait until it is completely dry before reinstalling it.

? In general, keeping all internal areas that are visible to consumers clean increases sales and improves the image of the machines.

? To access the lower trays (restocking area) open the machine's exterior door and take out the trays one at a time sliding them along their guides.

? There is a window on the back of the machine to allow air to circulate into it. This area and the cooling unit condenser, which is just next to it, should be cleaned periodically with a brush or compressed air to ensure it is not clogged with papers, bags or dust.

? The machine should never be cleaned with a water jet.

? The machine's interior should always be dry to ensure it works properly .

? When handling the cooling unit, always do so with the machine turned off and make sure that you do not bend any pipes, as they could break and produce a gas leak.

? It is very important never to touch any parts where there is LIVE VOLTAGE such as the power box and the wiring supplying the LED lights. To access these areas, open the machine's outside door and use a screw driver to remove the metal boxes protecting these components.

? Access to servicing area should only be permitted to persons with a knowledge of and practical experience in the machine, particularly with regard to health and safety.

? To clean the exterior of the machine, use a moist cloth with warm water and dry with a soft cloth.

? In case of persistent stains (grease, drinks, etc.), do not apply abrasive products. Do not use a cleaning spray! Use a solution of water and alcohol.

### 8.3. Recyclable

If you need to dispose of packaging materials consult your local authorities for recycling information.



Do not throw away any electronic circuit as many of the materials that they are made of are recyclable.

To manage the equipment as waste once the client has decided to dispose of it, **Jofemar** has set up a collection system with an Integrated Management System (ECOLEC). Please consult us for information about recycling.

## 8.4. Environment



Saving energy contributes to preserving the environment and, in the long run, helps save a considerable amount of money. This section contains advice on optimising the machine's use of energy as much as possible.

? The machine should be located in a cool, dry, well-ventilated place, so a location meeting these requirements should be sought within the facilities.

? Avoid the machine's direct exposure to sunlight. Use a parasol or sunshade if necessary.

? Ensuring the cooling unit grilles are always clean and well ventilated will result in significant energy savings and longer machine life

? There is an option in the MASTER machine or MASTER module to control when the machines lights go on and off. If you program the LED lighting to be on only during the hours of less light, when visibility is low, the annual savings will be significant. In locations with appropriate lighting, you can program the lights to be always off, in which case the energy savings will be considerable.

? Open the machine door only when necessary and keep it open for as short a period as possible. In locations without temperature regulation, product should be restocked during the coolest time of the day.

The machine's design process has been studied to ensure its has as little impact as possible on the environment, both in the use of raw materials and in its assembly, transport, service life and collection for recycling.

This section describes several material measures that show how **Jofemar** stands firm in its commitment:

? Lower energy consumption.

? Wood being replaced with plastic feet.

? The entire box made of cardboard has been avoided.

? Improving the machine thermal isolation.

## 9. Regulation

The machines of the **vision** product range have been designed to European standards as accredited by the **CE** mark on the machine data plate. **Jofemar** guarantees that these machines meet applicable directives.

**Vision Es-Plus // Vending**

